

- NOTES:
1. BLACK "TURTLE TILE" DECKING SHALL BE INSTALLED IN EACH TRAY
 2. THE "TURTLE TILE" DECKING SHALL HAVE A 2" DEEP BLACK TAPERED EDGE BETWEEN THE COMPARTMENT DOOR AND THE FRONT EDGE OF THE DECKING
 3. MUDFLAPS WILL BE PROVIDED AND INSTALLED TO THE REAR OF THE CHASSIS FRONT WHEELS
 4. THE FUEL TANK/DEF TANK/PASSENGER SIDE ENTRANCE STEP SHALL REMAIN AS SUPPLIED FROM CHASSIS MFG AND REAR TAILBOARD
 5. HEAVY DUTY HELPER STEPS TO BE ADDED BELOW CHASSIS CAB DOORS, PUMP PANEL RUNNING BOARDS AND REAR TAILBOARD
 6. THE CHASSIS VERTICAL EXHAUST SYSTEM SHALL HAVE IT'S STACK ADJUSTED TO THE HIGHEST POINT OF THE APPARATUS AFTER MFG
 7. STAINLESS STEEL HIGH HATS AND LUG NUT COVERS SHALL BE INSTALLED ON CHASSIS WHEELS
 8. THE ROLL-UP DOORS (INCLUDING THE OUTER FRAME) WILL BE PAINTED THE SAME COLOR AS THE APPARATUS BODY

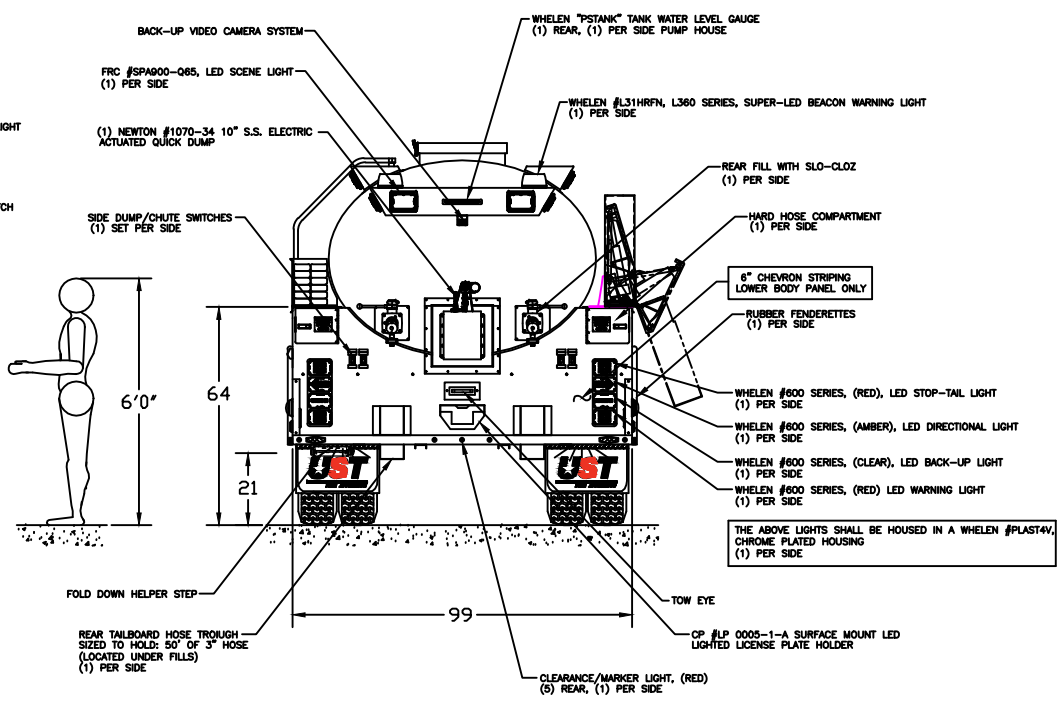
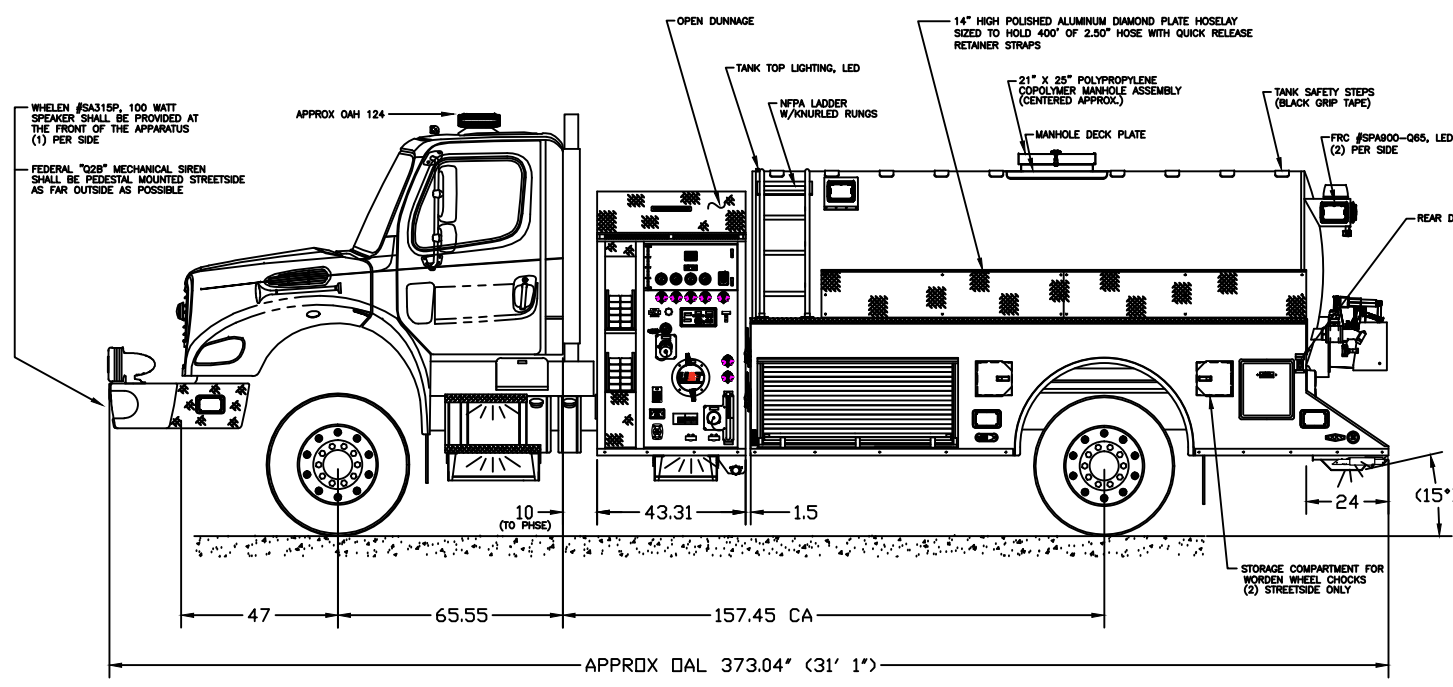

NOTE: PUMP PANEL LAYOUT SHOWN IS FOR REFERENCE ONLY

CUSTOMER APPROVAL		CUSTOMER	CONNESTEE FIRE DEPT.
THIS DRAWING IS ONLY A REPRESENTATION OF THE PRODUCT. EXACT LOCATION OF COMPONENTS MAY DIFFER DUE TO MANUFACTURING/SUPPLIER CHANGE. WRITTEN SPECIFICATIONS SUPERSEDE PRINTS		SIZE	2000 GALLON
SIGNATURE _____		TANK MATERIAL	POLYPROPYLENE COPOLYMER
TITLE _____		BODY MATERIAL	STAINLESS STEEL
DATE _____		CROSS SECTION	54.5 x 75 x 159" LG
CONCEPT <input type="checkbox"/> ORDER <input checked="" type="checkbox"/>		AFTERFRAME	58"
PROPOSAL <input type="checkbox"/> UST#U5674		PUMP	HALE MBP 750 GPM (PTO)
		TITLE	FREIGHTLINER M2112 4X4
		CHASSIS	FREIGHTLINER M2112 4X4
		DRAWN BY	JLB DATE 8/13/14

THIS DRAWING IS FOR REFERENCE ONLY



1827 HOBBS DR.
 DELAVAN, WI. 53115
 PHONE: 1-(800)-279-4911
 FAX: 1-(262)-757-7557
 E-MAIL SALES@USTANKER.COM
 WEBSITE: WWW.USTANKER.COM

COMPARTMENTATION	INSIDE DIMENSIONS		
	WIDTH	HEIGHT	DEPTH
STREETSIDE - FRONT	60"	28"	27"